

# SPARTAN 300

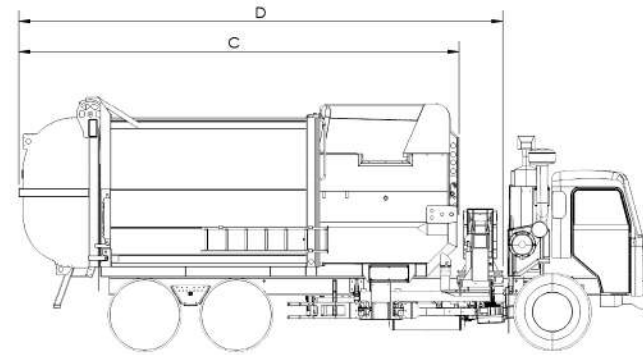
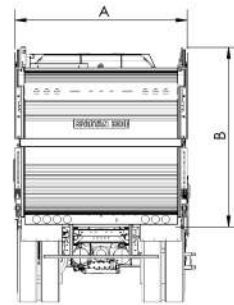

## BODY DIMENSIONS

	A	B	C	D	Pump Type	Vari. Displ. Piston Pump
28 Yd. Body	101.39"	105.8"	259.3"	285.1"	Oil Reservoir	75 Gallons
31 Yd. Body	101.39"	105.8"	274.3"	300.1"	Oil Flow Rate	60 GPM Packer @ 800 RPM 20 GPM Arm @ 800 RPM

## BODY SPECIFICATIONS

Body Floor	3/16" AR500	Arm and Packer Operating Pressure	2200 PSI
Tailgate	10 Gauge	Hydraulic Valve	5000 PSI Rated
Hopper Floor/Sides	1/4" AR500	Return Filter	10 Micron
Packer	1/4" AR500	High Pressure Filter	10 Micron
Roof	10 Gauge	System Fittings	37° Flare JIC

## CHASSIS SPECIFICATIONS

	Minimum GVWR	Minimum Usable C/T	Packer Cylinders	5.5" ID x 5" Rod
28 Yd. Body	64,000 lbs.	185"-195"	Compactor Cylinder	2.5" ID x 1.5" Rod
31 Yd. Body	64,000 lbs.	185"-195"	Arm Lift/Lower Cylinder	2.5" ID x 1.5" Rod

## ARM SPECIFICATIONS

Lift Capacity	2,000 Lbs.	Arm Dump/Undump Cylinder	2.5" ID x 1.375" Rod
Gripper Capacity	30-300 Gallon	Arm Grip/Release Cylinder	2.5" ID x 1.375" Rod
Controls	Electronic over Hydraulic	Arm In/Out Cylinder	2" ID x 1.25" Rod
Weight	2500 Lbs.	Clean-Out Cylinder	3" ID x 1.5" Rod
Daily Container Rating	1,200-1,500 Containers	Tailgate Cylinder	3" ID x 1.5" Rod

## PACKER SPECIFICATIONS

Cycle Time @ 800 RPM	25 Seconds	Arm Lubrication Points	Eleven (11)
Cycle Time @ 1500 RPM	18 Seconds	Body Lubrication Points	ZERO
Hopper Capacity	5 Cubic Yards		
Compaction	1,000 Lbs.		

## HYDRAULIC SPECIFICATIONS

	Vari. Displ. Piston Pump
Oil Reservoir	75 Gallons
Oil Flow Rate	60 GPM Packer @ 800 RPM 20 GPM Arm @ 800 RPM
Arm and Packer Operating Pressure	2200 PSI
Hydraulic Valve	5000 PSI Rated
Return Filter	10 Micron
High Pressure Filter	10 Micron
System Fittings	37° Flare JIC

## CYLINDER SPECIFICATIONS

Compactor Cylinder	2.5" ID x 1.5" Rod
Arm Lift/Lower Cylinder	2.5" ID x 1.5" Rod
Arm Dump/Undump Cylinder	2.5" ID x 1.375" Rod
Arm Grip/Release Cylinder	2.5" ID x 1.375" Rod
Arm In/Out Cylinder	2" ID x 1.25" Rod
Clean-Out Cylinder	3" ID x 1.5" Rod
Tailgate Cylinder	3" ID x 1.5" Rod

## LUBRICATION

Arm Lubrication Points	Eleven (11)
Body Lubrication Points	ZERO

## STANDARD EQUIPMENT

- Tip-to-Dump or Full Eject Body
- Constant drive PTO
- 30-90 gallon grippers
- Arm steady rest
- Hydraulic hopper cover
- Safety interlocks (warning indicators)
- In-cab rocker switch controls
- 7" display module for system functions
- Cable driven tailgate locking mechanism
- Rear and front mudflaps
- 1/2" AR Wear Strips on Body
- Powdercoated body, arm, and tailgate
- DOT compliant LED lighting

## OPTIONAL EQUIPMENT

- 30-300 gallon grippers
- Remote physical controller for system control module
- Camera system
- Hopper access ladder
- Joystick control
- Custom body and tailgate color
- Hot shift PTO
- Broom and shovel holder
- CNG fuel system
- Body mounted sign frames



# Spartan 300 Automated Side Loader

1441 N. VIP Blvd. Casa Grande, AZ 85122 • 12266 Branford St. Sun Valley, CA 91352

602-584-5001 • 818-899-1111

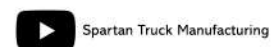

www.spartantruck.com



# Innovation Still At Work

## The Hydraulic System

- 180° Operating Temperature (114° Ambient)
- Single 8 Stack Hydraulic Valve for Body & Arm Functions (5000 PSI Rated)
- Variable Displacement Piston Pump for On-Demand Oil Flow
  - 75 Gallon Aluminum Hydraulic Tank
  - 2500 PSI System Pressure
- System Utilizes 37° Flare JIC Fittings



## Hopper and Compaction

- 5 Yd. Hopper
- Deepest Packer Penetration into Body at 12" and 24" (Operator Controlled)
- Single Piece Follower Panel
- Hopper Cover is Dual Purpose as Compaction Panel

## The Packer Blade

- AR500 Construction
- Parallel Mounted Packer Cylinders versus Cross Mounted
- 8x8 Horizontal Tubes Protect the Packer Cylinders

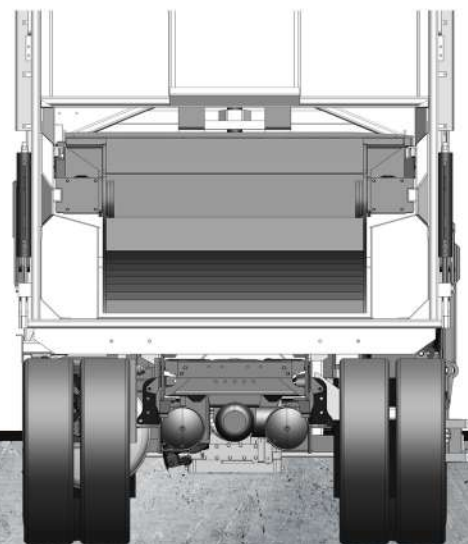

## The Automated Arm

- 2,000 Lb. Continuous Lift Capacity
- 1,200 to 1,500 Cans Per Day
- 8 Foot Reach
- 30-300 Gallon Container Lift Capability
- Pivot Point Designed to Minimize Kickout
- Composite Wear Strips for Simple Maintenance on Inner & Outer Arm
- Standard Dump Arm Steady Rest

